

Fire dampers installed in oversized wall openings

These fabricated galvanized steel mullions are intended to sub divide a large vertical wall opening into smaller openings. These smaller openings are not to exceed the maximum size restrictions of the UL Classified 1½ or 3 hour rated galvanized steel fire damper assembly.

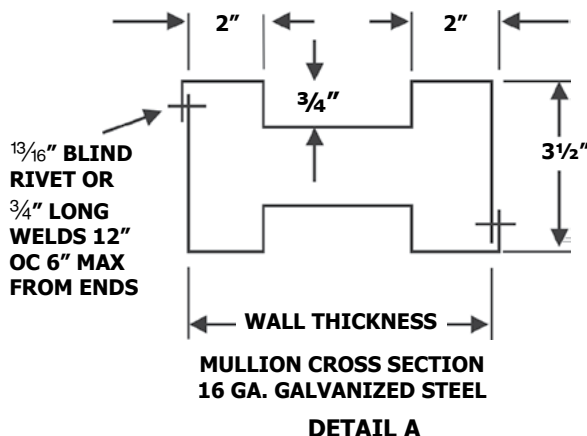
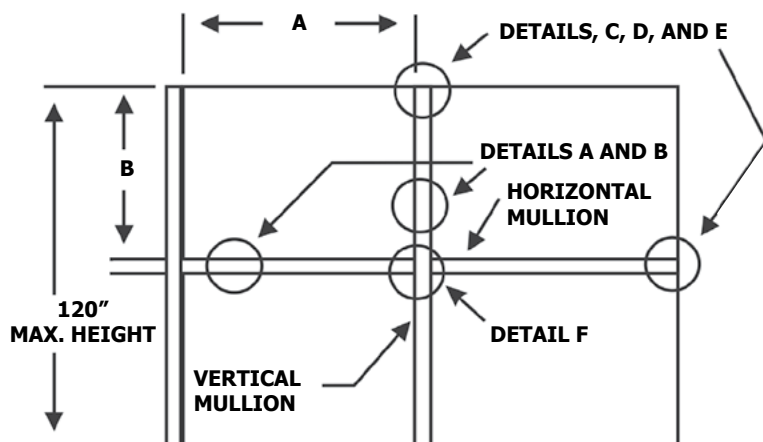

"A" and "B" opening sizes are not to exceed the damper's approved maximum multiple assembly size. Vertical, horizontal, or vertical and horizontal mullions can be used, depending on the opening size.

CONDITIONS & RESTRICTIONS

- Fabricated from galvanized steel with a normal yield strength of 42,000 psi.
- Intended for use in concrete block or poured walls only with a minimum wall thickness of 7" and a maximum wall thickness of 12".
- To permit proper embedding of anchors, hollow concrete block walls are to be filled at the opening by minimum 3,500 psi concrete.
- Steel mullions are not to be inside the ductwork. For ducted systems, each sub-divided opening must be individually ducted.

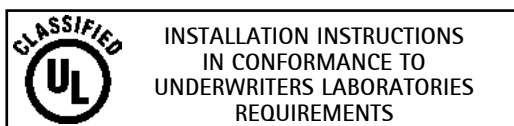
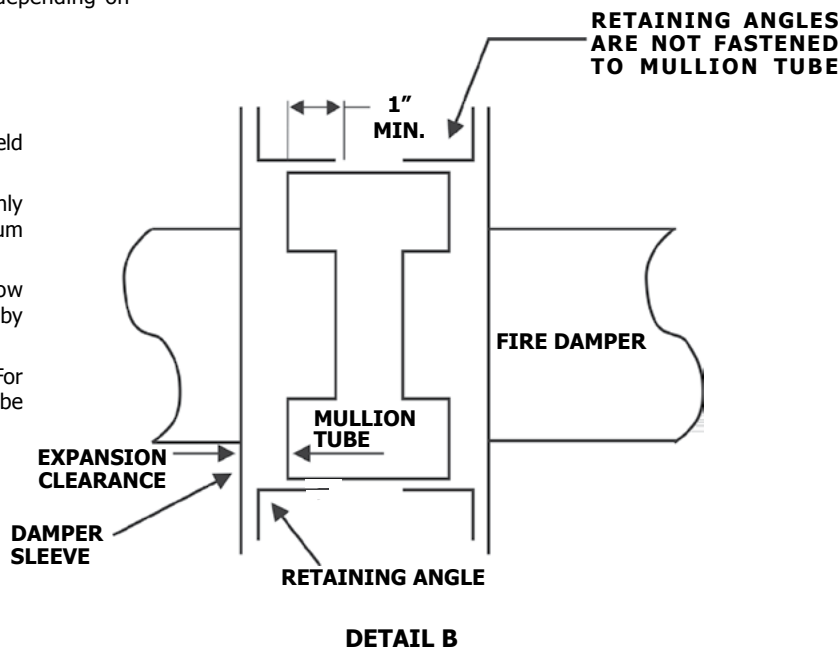

Reference the damper's installation instructions regarding the approved method of attaching the damper to the sleeve, attaching the retaining angles to the sleeve, required expansion clearances, sleeve gauge, etc.

Fire dampers installed in oversized wall openings

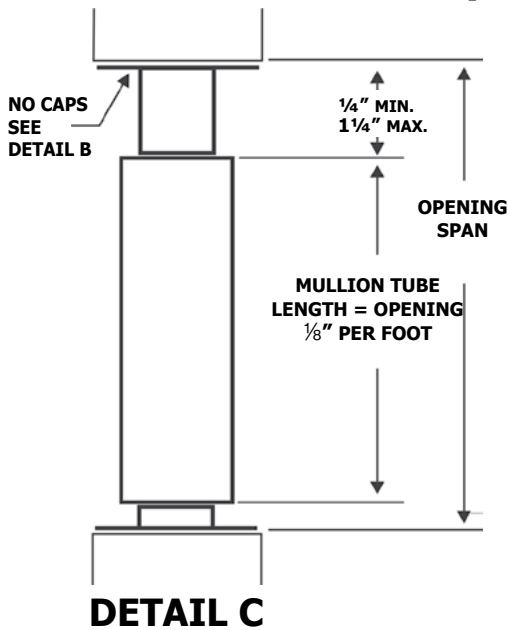

The end caps are attached by means of 1" long X 3/8" dia. steel expansion anchors embedded into the opening with 1/2" dia. flat head machine screws, eight per end cap. If a steel lintel is used, four 1" long welds per end cap (two per leg) may be used.

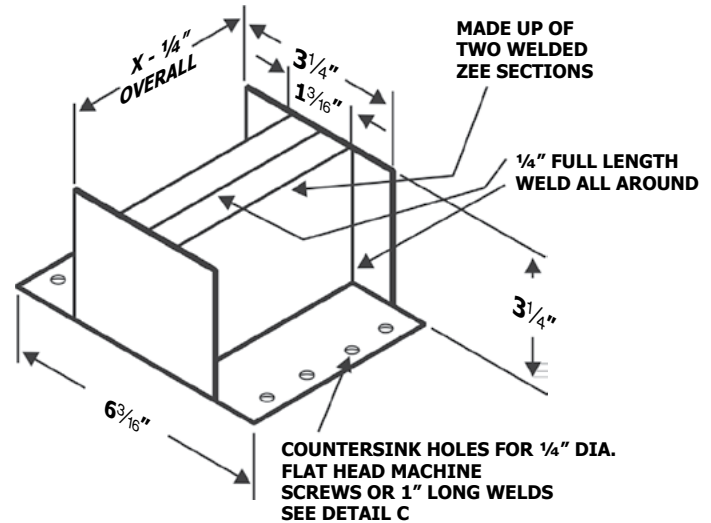

DETAIL D

Top bottom or side end caps
12GA galvanized steel.

X = WALL THICKNESS

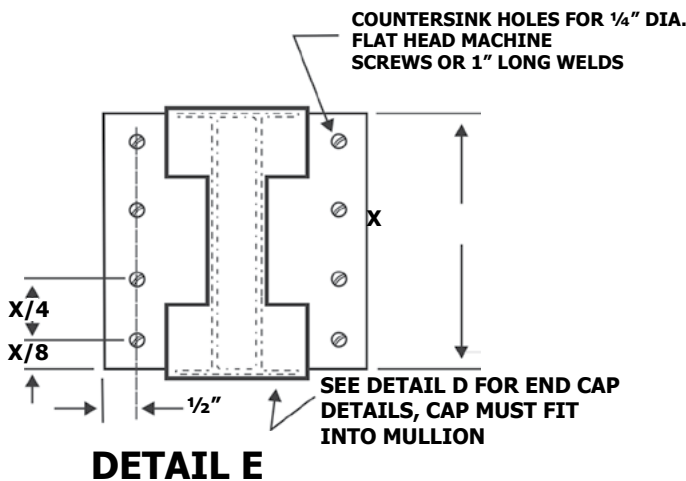

All horizontal and vertical mullion tubes must be terminated with an end cap. These end caps may not be fastened to the mullion tube and must slide freely inside the mullion tube.

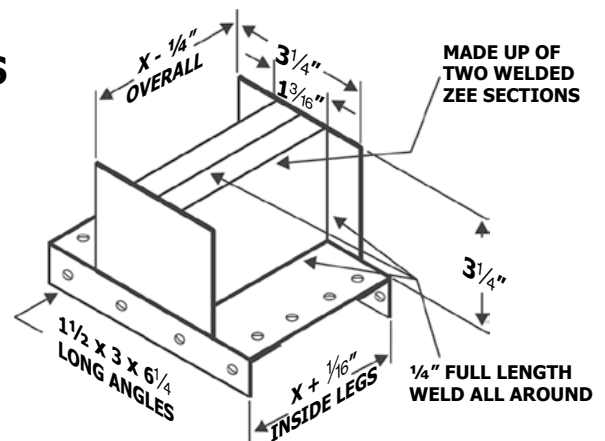

DETAIL F

Attach the horizontal mullion end caps to the vertical mullion tube by means of (12) 3/16" dia. blind rivets or by 1/8" full length weld.



INSTALLATION INSTRUCTIONS
IN CONFORMANCE TO
UNDERWRITERS LABORATORIES
REQUIREMENTS